

CHROMAFLOOD CHROMABATTEN



SPECIFICATION

CFLD100	- ChromaFlood100 – 5,8,25,45,12x25,10x90 lenses
CFLD200	- ChromaFlood200 – 8,25,45,12x25,10x90 lenses
CBAT100	- ChromaBatten100 – 10, 25 and 45 degree lenses
CBAT200	- ChromaBatten200 – 10, 25 and 45 degree lenses
CBAT300	- ChromaBatten300 – 10, 25 and 45 degree lenses

The **ChromaFlood** and **ChromaBatten** contain state of the art, high brightness, high efficiency Red, Green and Blue LEDs. These three primary colours can be mixed together to make an incredible palette of 16.7 million colours.

They are IP65 rated fixtures and therefore suitable for outdoor or indoor use. They are powered directly from 100-240 Volts AC and have full remote DMX control of RGB levels or can function in Stand Alone Mode. Numerous chases and sequences are built in, enabling superb lighting effects without complicated programming.

These impressive fixtures are ideal for the architectural and entertainment markets to give an unlimited colour palette that can enhance building facades, water features and focal displays or to providing stunning dynamic colour in shows, conferences, concerts and themed environments.

Like the **ChromaBank**, the **ChromaFlood** and **ChromaBatten** contain a **PULSAR ChromaZone** controller and can therefore also operate in 3, 6, 9, 10, 36, 42 or 46 Channel Modes.

It is useful to consider the **ChromaFlood** as being 1 of the 12 fixtures, and the **ChromaBatten** as being, either 1 or 3, of the 12 fixtures, within a **ChromaBank**.

Please see the **Channel Assignments Tables** sheet for details of the different modes.

The **ChromaFlood** and **ChromaBatten** have numerous chases and effects built in, making it possible to achieve fantastic effects without programming. These internal effects can be selected via the **User Interface Module** (UIM) on the rear of the units whilst in Stand Alone mode, or from a controller using a digital **PMX** (Pulsar MultipleX) or **DMX** (Digital MultipleX) signal.

Please see the **Menu Selection Overview** sheet for a pictorial representation of the menu functions.

The **ChromaFlood** and **ChromaBatten** have mounting brackets making them ideal for floor, wall, ceiling or rig mounting. The **ChromaFlood** picture at the top of this page shows the mounting brackets arranged for floor mounting.

ChromaFlood and **ChromaBatten** have a colour code letter. This signifies the finished colour of the fixture (B = Black, S = Silver). Other colours may become available - please check with Pulsar if required.

The **ChromaFlood** and **ChromaBatten** have a thermal management system. This progressively reduces the power to the LEDs if the internal temperature exceeds limits set by the software.

Excess temperature will occur if the units are exposed to high ambient temperatures or inadvertently covered. It is therefore important for maximum performance that they have good ventilation on all sides.

The lenses shipped with the **ChromaFlood** and **ChromaBatten** may be easily changed. Currently 5 (ChromaFlood100 only), 8, 25, 45, 12x25 (elliptical) and 10x90 (elliptical) lens plates are available for the **ChromaFlood** with 10, 25 and 45 degree lenses available for the **ChromaBatten**.

Other lenses may become available, please contact **Pulsar** or see www.pulsarlight.com for details

NB - Patents applied for

CONNECTIONS

Mains Supply - The **ChromaFlood** and **ChromaBatten** work correctly on any mains voltage from 100-240 VAC, 50-60Hz, (self adjusting). Power consumption is 200 Watts max.

A 5m, bare ended, mains cable is provided. The bare end of the cable should be fitted with a suitably approved and rated mains plug. Note: in some countries it is a requirement that such a plug be fitted by a qualified electrician.

CABLE COLOURS

Green/Yellow = \perp Earth / Ground
Brown = Live / Phase / Hot
Blue = Neutral

WARNING - THIS APPLIANCE MUST BE EARTHED

For safety we recommend the use of a Residual Current Circuit Breaker. An RCCB MUST be used when powering a ChromaFlood or ChromaBatten in wet environments.

PMX/DMX In/Thru 5 Pin XLR Connectors

Digital Control Signals: Two 5 pin XLR connectors on 5m cables (in/thru) are provided. The pin connections of the sockets are:

PMX (RS232/423) SIGNAL	DMX SIGNAL
Pin 1 = Screen / Chassis Earth	Pin 1 = Screen / Chassis Earth
Pin 2 = Signal (Blue)	Pin 2 = Signal -
Pin 3 = Signal Earth (White)	Pin 3 = Signal +
Pin 4 = no connection (Green)	Pin 4 = no connection
Pin 5 = LVS (male only) (Red)	Pin 5 = LVS (male only)



Wet / Damp Environment Use – these products are IP65 rated. However, the cable connections **must** also be contained in a dry, low humidity, environment as water and vapour will travel inside the cables from the connection joints into the fixture. A waterproof connection box, or properly fitted IP68 rated connectors, are essential for cable connections in such environments. Suitable connectors are available from Pulsar.

Failure to take these precautions invalidates the guarantee.



USER INTERFACE MODULE AND FUNCTIONS

LCD DISPLAY A 2 line, 16 character per line, LCD display is used to set up, and indicate the status of, the **ChromaFlood and ChromaBatten**.

At switch on, the display shows:

```
DMX Address: n (where n=1 to 512)
Receiving: NO SIGNAL or DMX or PMX or ERROR
```

Press the \uparrow (Up) or \downarrow (Down) keys to cycle through the Menu Options (see *LCD Display Sheet*).

Press the **X** key on the **UIM** to change the settings.

Note: Program Mode self cancels after ~30 seconds if no keys have been pressed.

Note: if, at any time, the display shows **Receiving: ERROR**, then there is a problem with the DMX signal. It could be wiring, termination or poorly implemented DMX.

? DMX Address – depending on the operating mode, a block of 3, 6, 9, 10, 36, 42 or 46 channels is received from the DMX signal – see *Channel Assignments Tables*. The **DMX Address** is the number of the first channel in the block.

To set the required **DMX Address**, press the \uparrow or \downarrow keys on the **UIM** until the display shows **DMX Address**:

Press the **X (change)** key on the **UIM**, then set the start address using the \uparrow or \downarrow keys. These keys repeat if held down.

When the required **DMX Address** number shows in the display, press the \checkmark (**Yes**) key to save changes or **X (Back)** key to restore the previous settings.

Note: the **Receiving:** text (NO SIGNAL / PMX / DMX / ERROR) in the display is for information only.

? ChromaZone Mode - the unit can be run in similar modes to the ChromaZone. The options are 3, 6, 9, 10, 36, 42 and 46 channel modes – see *Channel Assignments Tables*.

To set the required **Mode**, press the \uparrow or \downarrow keys on the **UIM** until the display shows **ChromaZone Mode**:

Press the **X (change)** key on the **UIM**, then select the required mode using the \uparrow or \downarrow keys.

When the required **ChromaZone Mode** shows in the display, press the \checkmark (**Yes**) key to save changes or **X (Back)** key to restore the previous settings.

? Channels per Fixture – the **CFLD** and **CBAT** can be run in 3 channels per fixture or 6(**CFLD**) / 9(**CBAT**) channels per fixture modes. The 6/9 channel modes allow a chase to be run across the fixture. This is particularly effective in the **CBAT** where the Batten is divided into 3 fixtures, each of RGB.

To set the required number of **Channels per Fixture**, press the \uparrow or \downarrow keys on the **UIM** until the display shows **Channels per Fixture** :

Press the **X (change)** key on the **UIM**, then select the required number using the \uparrow or \downarrow keys.

When the required number of **Channels per Fixture** shows in the display, press the \checkmark (**Yes**) key to save changes or **X (Back)** key to restore the previous settings.

? Fixture number: the 36 RGB outputs from the built in ChromaZone are divided into fixture groups. 36 divided by the channels per fixture (set above) gives the number of fixtures available from the data block.

For example, if you set the channels per fixture on a **CBAT** to 9, the maximum number of fixtures available will be 4. See the *Channel Assignments Table* for channel and fixture number colour details.

To set the required **fixture number**, press the \uparrow or \downarrow keys on the **UIM** until the display shows **Fixture number**:

Press the **X (change)** key on the **UIM**, then select the required number using the \uparrow or \downarrow keys.

When the required **Fixture number** shows in the display, press the \checkmark (**Yes**) key to save changes or **X (Back)** key to restore the previous settings.

? Chase patterns: may be **6 or 12 way**. E.g. two **CBATs** set for 9 Channels per Fixture (3 x RGB) will run a 6 way chase.

To set the required **chase patterns**, press the \uparrow or \downarrow keys on the **UIM** until the display shows **Chase patterns**:

Press the **X (change)** key on the **UIM**, then select **6 or 12 way** using the \uparrow or \downarrow keys.

When the required **chase pattern way number** shows in the display, press the \checkmark (**Yes**) key to save changes or **X (Back)** key to restore the previous settings.

? Channel 10: may be set as a Grand Master for the 36 RGB channels only, OR as a Global Grand Master for the 36 RGB channels, the ALL Red, Green and Blue, and the Chase Levels. To set the required **Ch.10** mode of operation, press the \uparrow or \downarrow keys on the **UIM** until the display shows **Ch.10...**:

Press the **X (change)** key on the **UIM**, then select the required number using the \uparrow or \downarrow keys.

When the required **Ch.10** operation shows in the display, press the \checkmark (**Yes**) key to save changes or **X (Back)** key to restore the previous settings.

? Input Smoothing - ON or OFF. To disable the input smoothing, e.g. for fast response to video graphics signals, set to **OFF**

To turn the **Input Smoothing** ON/OFF, press the \uparrow or \downarrow keys on the **UIM** until the display shows **Input Smoothing**:

Press the **X (change)** key on the **UIM**, then select the required state using the \uparrow or \downarrow keys.

When the required state shows in the display, press the \checkmark (**Yes**) key to save changes or **X (Back)** key to restore the previous settings.

? Low Voltage Supply - ON or OFF. To connect the LVS to pin 5 of the MALE XLR, set to **ON**.

The LVS is used to power some PULSAR controllers, e.g. Outstation OS1. 24V at up to 250mA d.c. is available.

To turn the **Low Voltage Supply** ON/OFF, press the \uparrow or \downarrow keys on the **UIM** until the display shows **Low Voltage Supply is**:

Press the **X (change)** key on the **UIM**, then select the required state using the \uparrow or \downarrow keys.

When the required state shows in the display, press the \checkmark (**Yes**) key to save changes or **X (Back)** key to restore the previous settings.

? DMX Line Termination – ON or OFF, set the last unit in the DMX cable run to **ON**, all others to **OFF**. Errors can often occur if the DMX line is not terminated. DMX errors are shown in the display as:

```
DMX Address: n
Receiving: ERROR
```

To turn the **DMX Line Termination** ON/OFF, press the \uparrow or \downarrow keys on the **UIM** until the display shows **DMX Line Termination**:

Press the **X (change)** key on the **UIM**, then select the required state using the \uparrow or \downarrow keys.

When the required state shows in the display, press the \checkmark (**Yes**) key to save changes or **X (Back)** key to restore the previous settings.

? If NoSignal use: In the event the **CFLD** or **CBAT** is not receiving a DMX signal (e.g. controller no longer present), the unit may either use the user-programmable Stand Alone Settings (see *Stand Alone Settings View/Change* below) OR continue to use the Last DMX Packet received.

To select the **If NoSignal use:** requirement, press the \uparrow or \downarrow keys on the **UIM** until the display shows **If NoSignal use**

Press the **X (change)** key on the **UIM**, then select the requirement using the \uparrow or \downarrow keys.

When your requirement is showing in the display, press the \checkmark (**Yes**) key to save changes or **X (Back)** key to restore the previous settings.

? Stand Alone Settings View/Change

There are three possibilities depending on:

- whether there is an input signal and
- whether "If NoSignal use:" is set to "Stand Alone Mode" or set to "Last DMX Packet".

1. No Signal + Use Stand Alone Mode:

The current Stand Alone Settings may be viewed, changed and saved as the new Stand Alone Settings.

2. No Signal + Use Last DMX Packet:

The channel levels of the Last DMX Packet (if any) may be viewed, changed and saved as the new Stand Alone Settings.

3. Signal present:

The incoming signal overwrites any changes made but these incoming channel levels may be set at the controller, viewed and saved as the new Stand Alone Settings.

CHROMAFLOOD CHROMABATTEN

USER INTERFACE MODULE AND FUNCTIONS

Stand Alone Settings View/Change (continued)

To View/Change the Stand Alone Settings, press the \uparrow or \downarrow keys on the **UIM** until the display shows **Stand Alone Settings View/Change**.

Press the **X (change)** key on the **UIM**, then select the channel to view/change using the \leftarrow or \rightarrow keys. These keys repeat if held down. When the channel to be viewed/changed is showing in the display, press the \uparrow or \downarrow keys to change the value. These keys repeat if held down. The display shows both the bit number (0-255) and percentage (0-100%).

Please see the **Chase Select Table** when modifying chases.

To modify further channels, select the channel to view/change using the \leftarrow or \rightarrow repeat keys, pressing the \uparrow or \downarrow repeat keys to change the value.

When you have finished modifying channels, press the \checkmark (**Yes**) key to save changes or **X (Back)** key to restore the previous settings.

? VIEW(Sig)/SET(NoSig) Chan Levels

To View the Channel Levels/Change the Stand Alone Settings, press the \uparrow or \downarrow keys on the **UIM** until the display shows **VIEW(Sig)/SET(NoSig) Chan Levels**

Press the **X (change)** key on the **UIM**, then select the channel to change/view using the \leftarrow or \rightarrow keys. These keys repeat if held down.

When the channel to be changed/viewed is showing in the display, press the \uparrow or \downarrow keys to change the value. These keys repeat if held down. The display shows both percentage (0-100%) and bit number (0-255), and for channels 4 (Chase 1 Select) and 7 (Chase 2 Select) the chases selected.

Please see the **Chase Select Table** when modifying chases.

Notes:

- this menu item is for this session use only, data is never saved.
- the values can only be changed if the unit is not receiving data.
- pressing the **X** or \checkmark keys returns to the main menu.

? Restore Factory Default Settings

To restore the factory default settings, press the \uparrow or \downarrow keys on the **UIM** until the display shows **Restore Factory Default Settings**.

Press the **X (change)** key on the **UIM**, then press the \checkmark (**Yes**) key to restore defaults or **X (Back)** key to exit.

The factory default settings are

DMX Address	1	
ChromaZone Mode	46 Channel	
Channels per Fixture	3 (CFLD) / 9 (CBAT)	
Fixture number	1	
Chase patterns	12 Way	
Channel 10	Grand Master for the 36 RGBs only	
Input Smoothing	ON	
Low Voltage Supply	ON	
DMX Line Termination	OFF	
If NoSignal use:	Stand Alone Mode	
Stand Alone Settings	Ch.1 – 3	= 0 bits / 0%
	Ch.4 = Chase 1 Select	= Auto Chase
	Ch.5 = Chase 1 Speed	= 128 bits / 50%
	Ch.6 = Chase 1 Level	= 255 bits / 100%
	Ch.7 – 46	= 0 bits / 0%

OTHER INFORMATION

Failure of the internal **ChromaFlood** or **ChromaBatten 5 Amp, 5x20mm Power Supply Fuse**, usually indicates an internal fault requiring servicing by a qualified engineer.

If the front glass becomes cracked or broken, disconnect from the mains immediately and have the unit repaired. Replacement glasses are available from Pulsar.

The PMX/DMX connections (input and thru) are protected against inadvertent shorts to 240Vac and static damage.

PORTABLE APPLIANCE TESTING - The **Pulsar ChromaFlood** and **ChromaBatten** may be safely Earth Bond and Insulation Tested.

STANDARDS - The **Pulsar ChromaFlood** and **ChromaBatten** comply with the following International and National Standards:

Electrical Safety - IEC65, EN60065, BS415

EMC - EN50081-1, EN55022, EN50082-1

Index of Protection - IP65



Marking Directive 93/68/EEC - The **Pulsar ChromaFlood** and **ChromaBatten** both meet the EMC Directive 89/336/EEC and the Low Voltage Directive 73/23/EEC.



Conforms to: ANSI/UL Standard 6500
Certified to: CAN/CSA-E60065-00

3048422

GUARANTEE - 12 months from the date of original purchase. The guarantee is limited to parts and labour. The guarantee is void if the unit is misused, the cable connections are not in a dry environment or made using an IP68 rated connector, or unauthorised persons perform repairs. In the unlikely event of a fault occurring, do not use without repair. Return the unit to your supplier with a description of the fault, or direct to Pulsar for immediate attention

DIMENSIONS AND WEIGHTS

Code	Unit	Width	Height	Depth	Weight
		mm	mm	mm	kg
CFLD200	ChromaFlood200	365.0	373.0	118.0	8.0
CBAT200	ChromaBatten200	1198.0	132.0	132.0	12.4



Instructions

ChromaFlood100 and ChromaFlood200 Mechanical Details

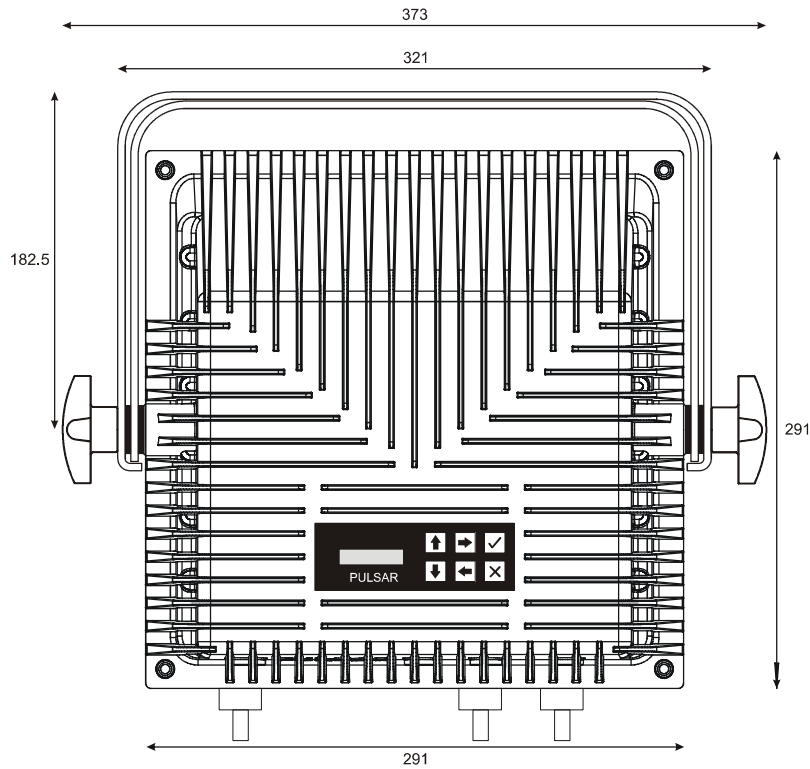

AVAILABLE ANGULAR MOVEMENT WHEN FLOOR MOUNTED ON HANGERS SUPPLIED

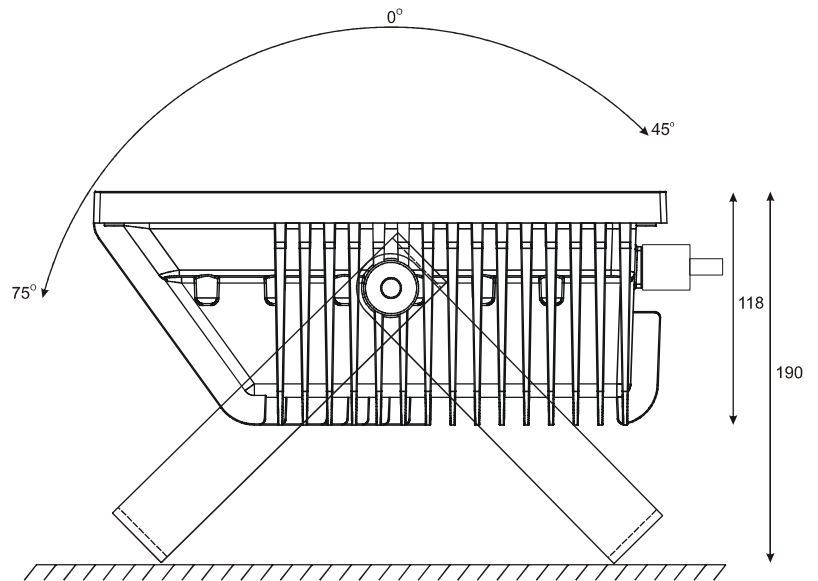

Correct Locations of Fitment of Washers

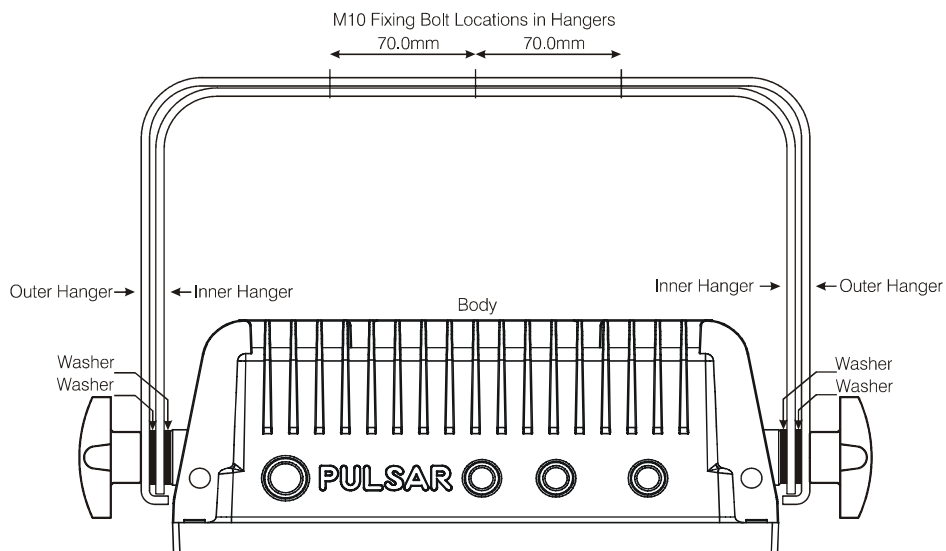

CHROMAFLOOD AND CHROMABATTEN CHANNEL ASSIGNMENTS TABLES

3 Channel Mode	
1	All Red
2	All Green
3	All Blue

6 Channel Mode	
1	All Red
2	All Green
3	All Blue
4	Chase Select (see Chase Table)
5	Chase Speed
6	Chase Level

9 Channel Mode	
1	All Red
2	All Green
3	All Blue
4	Chase1 Select (see Chase Table)
5	Chase1 Speed
6	Chase1 Level
7	Chase2 Select (see Chase Table)
8	Chase2 Speed
9	Chase2 Level

10 Channel Mode	
1	All Red
2	All Green
3	All Blue
4	Chase1 Select (see Chase Table)
5	Chase1 Speed
6	Chase1 Level
7	Chase2 Select (see Chase Table)
8	Chase2 Speed
9	Chase2 Level
10	Global Grand Master

36 Channel Mode		
3 Channels / Fixture	6 Channels / Fixture	9 Channels / Fixture
1 Fixture 1 Red	1 Fixture 1 Red 1	1 Fixture 1 Red 1
2 Fixture 1 Green	2 Fixture 1 Green 1	2 Fixture 1 Green 1
3 Fixture 1 Blue	3 Fixture 1 Blue 1	3 Fixture 1 Blue 1
4 Fixture 2 Red	4 Fixture 1 Red 2	4 Fixture 1 Red 2
5 Fixture 2 Green	5 Fixture 1 Green 2	5 Fixture 1 Green 2
6 Fixture 2 Blue	6 Fixture 1 Blue 2	6 Fixture 1 Blue 2
↓	↓	↓
36 Fixture 12 Blue	36 Fixture 6 Blue 2	36 Fixture 4 Blue 3

42 Channel Mode		
3 Channels / Fixture	6 Channels / Fixture	9 Channels / Fixture
1-6 as 6 Channel Mode	1-6 as 6 Channel Mode	1-6 as 6 Channel Mode
7 Fixture 1 Red	7 Fixture 1 Red 1	7 Fixture 1 Red 1
8 Fixture 1 Green	8 Fixture 1 Green 1	8 Fixture 1 Green 1
9 Fixture 1 Blue	9 Fixture 1 Blue 1	9 Fixture 1 Blue 1
10 Fixture 2 Red	10 Fixture 1 Red 2	10 Fixture 1 Red 2
11 Fixture 2 Green	11 Fixture 1 Green 2	11 Fixture 1 Green 2
12 Fixture 2 Blue	12 Fixture 1 Blue 2	12 Fixture 1 Blue 2
↓	↓	↓
42 Fixture 12 Blue	42 Fixture 6 Blue 2	42 Fixture 4 Blue 3

46 Channel Mode		
3 Channels / Fixture	6 Channels / Fixture	9 Channels / Fixture
1-9 as 9 Channel Mode	1-9 as 9 Channel Mode	1-9 as 9 Channel Mode
10 36xRGB Grand Master	10 36xRGB Grand Master	10 36xRGB Grand Master
OR	OR	OR
10 Global Grand Master	10 Global Grand Master	10 Global Grand Master
11 Fixture 1 Red	11 Fixture 1 Red 1	11 Fixture 1 Red 1
12 Fixture 1 Green	12 Fixture 1 Green 1	12 Fixture 1 Green 1
13 Fixture 1 Blue	13 Fixture 1 Blue 1	13 Fixture 1 Blue 1
14 Fixture 2 Red	14 Fixture 2 Red 2	14 Fixture 1 Red 2
15 Fixture 2 Green	15 Fixture 2 Green 2	15 Fixture 1 Green 2
16 Fixture 2 Blue	16 Fixture 2 Blue 2	16 Fixture 1 Blue 2
↓	↓	↓
46 Fixture 12 Blue	46 Fixture 6 Blue 2	46 Fixture 4 Blue 3

Instructions



ChromaZone™ Software Version 4.0

Pulsar ChromaZone / ChromaBank / ChromaFlood / ChromaBatten Software Version No. 4.0 (MAIN micro 4.0 09-09-05 or later + UIM micro 1.0 07-03-05 or later) has many exciting features. • Two built in Chases – allowing superimposition of effects and crossfading between chases. Chase 1 and 2 use the same table of 31 chases but there are differences to give you more choice - Chase 1 uses the ALL Red, Green and Blue Channels, 1, 2 & 3, to change the colour of some chases (see table) while Chase 2 stays white and uses them to give a background colour. The chases have a very wide range of speeds.

- 7 operating modes: 3, 6, 9, 10, 36, 42 and 46 Channel Modes.
- A Master Dimmer Channel (Ch.10) for the 36 individual RGB channels, which may become a Global Grand Master for the All R/G/B and Chases Levels too.
- Input Smoothing may be disabled for fast display of video graphics and video frame rate capability.
- Please see the **Channel Assignments Table** page for details of the Operating Modes and how to select them, Channel Listings, and further information.

Chase	%	Bit	Chase	Notes
No.	Input	No.	Description	
15	100	255	Auto Chase	
	95	244	Green Yellow Red Bar Graph Reverse	Use Channel1
	92	236	Green Yellow Red Bar Graph Forward	Use Channel1
14	89	228	Rainbow Strobe	
13	86	220	White / Any Colour Strobe	Channels 1, 2 & 3 set colour
	83	212	White / Any Colour Crossover	Channels 1, 2 & 3 set colour
12	80	204	Blue-Yellow Wave Reverse	
	77	196	Blue-Yellow Wave Forward	
	73	188	Green-Magenta Wave Reverse	
11	70	180	Green-Magenta Wave Forward	
	67	172	Red-Cyan / AnyCol/Op.Col Wave Forward	Channels 1, 2 & 3 set colour
10	64	164	Red-Cyan / AnyCol/Op.Col Wave Reverse	All 3 at 0% = Red-Cyan
9	61	156	Black-White/AnyColour Wave Forward	Channels 1, 2 & 3 set colour
	58	148	Black-White/AnyColour Wave Reverse	All 3 at 0% = White.
8	55	140	Random Cols. Chase1 Crossfade, Chase2 Snap	
	52	132	Rainbow 2 Crossfade Forward	Wider primary colours to compensate for extra diffusion
	48	124	Rainbow 2 Crossfade Reverse	
7	45	116	Rainbow Crossfade Forward	Equal width primary & secondary colours
6	42	108	Rainbow Crossfade Reverse	
	39	100	"Follow 3" 18 Contrasting Colours Reverse	
5	36	92	"Follow 3" 18 Contrasting Colours Forward	
	33	84	18 Crossfading Colours Reverse	
4	30	76	18 Crossfading Colours Forward	
	27	68	White/AnyColour/AutoColour Cascade Reverse	Channels 1, 2 & 3 set colour. All 3 at 0% = White. All 3 at 100% = Auto Colour Change
	23	60	White/AnyColour/AutoColour Cascade Forward	
3	20	52	6 Crossfading Pastel Colours	
	17	44	Colour Wipes	
2	14	36	6 Crossfading Colours	
1	11	28	6 Separate Colours	
	8	20	Red Green Blue Bar Graphs Reverse	Use Channels 1, 2 & 3
	5	12	Red Green Blue Bar Graphs Forward	Use Channels 1, 2 & 3
0	0	0	No Chase	

CHROMAFLOOD AND CHROMABATTEN MENU SELECTION OVERVIEW

Display	Operation	Display	Choices	Operation
DMX Address: <i>n</i> Receiving: <i>t</i>	X=Change X=Restore	DMX Address <i>n</i> ↑↓ X=Back ✓=Yes	<i>n</i> =1 to 512 <i>t</i> = DMX / PMX / NO SIG / ERROR	✓ =Save
ChromaZone Mode: <i>nn</i> Channels	X=Change X=Restore	CZ Mode <i>nn</i> Chan. ↑↓ X=Back ✓=Yes	3 6 9 10 36 42 46	✓ =Save
Channels per Fixture: <i>n</i>	X=Change X=Restore	Chs/Fixture: <i>n</i> ↑↓ X=Back ✓=Yes	3 6 (FLOOD) / 9 (BATTEN)	✓ =Save
Fixture number: <i>n</i> of <i>x</i>	X=Change X=Restore	Fixture <i>n</i> of <i>x</i> ↑↓ X=Back ✓=Yes	1-12 of 12 1-6 of 6 (FLD) / 1-4 of 4 (BAT)	✓ =Save
Chase patterns: <i>n</i> Way	X=Change X=Restore	<i>n</i> Way Patterns ↑↓ X=Back ✓=Yes	6 Way 12 Way	✓ =Save
Ch.10	X=Change X=Restore	↑↓ X=Back ✓=Yes	CH10 = 36xRGB GM CH10 = Global GM	✓ =Save
Input Smoothing: <i>t</i>	X=Change X=Restore	IP Smoothing <i>t</i> ↑↓ X=Back ✓=Yes	ON=Gentle, Smooth OFF=Fast, Video	✓ =Save
Low Voltage Supply is: <i>t</i>	X=Change X=Restore	LV Supply is <i>t</i> ↑↓ X=Back ✓=Yes	ON OFF	✓ =Save
DMX Line Termination: <i>t</i>	X=Change X=Restore	Line Term is <i>t</i> ↑↓ X=Back ✓=Yes	ON OFF	✓ =Save
If NoSignal use: <i>t</i>	X=Change X=Restore	<i>t</i> ↑↓ X=Back ✓=Yes	Stand Alone Mode Last DMX Packet	✓ =Save
Stand Alone Sett ings View/Change	X=Change X=Restore	Bits: %	Channel Assignments Tables and Chase Select Table	✓ =Save
VIEW(Sig)/SET(No Sig) Chan Levels	X=View X=Back	Bits: %	Channel Assignments Tables and Chase Select Table	X = Back ✓ = Back
Restore Factory Default Settings	X=View X=Back	Restore Defaults X=Back ✓=Yes	✓=Restore	
Pulsar Light of Cambridge Ltd UK		Information only		
www. pulsarlight.com		Information only		
MainSoftware <i>N.n</i> (C)Pulsar <i>cdmmyy</i>		Information only		
UIM Software <i>N.n</i> (C)Pulsar <i>cdmmyy</i>		Information only		
Inside air units now <i>xxx</i> was <i>yyy</i>		Information only Used by software		
↑↓ to view X to change		Information only		

Instructions



IMPORTANT SAFETY INSTRUCTIONS

Read the Product Instruction Leaflet and this Safety Instructions Leaflet before attempting to install or operate this apparatus.

Keep this leaflet and the Product Instruction Leaflet for future reference.

Observe ALL warnings indicated by the  symbol, both in the Product Instruction Leaflet and on the apparatus.

Follow ALL instructions given in the Product Instruction and this Safety Leaflet. Failure to do so may result in serious injury or death.

Protect the power cord from being walked on or pinched, particularly at plugs, auxiliary outputs, and the point where they exit from the apparatus.

Only use attachments/accessories specified by the manufacturer (Pulsar Light of Cambridge Ltd. UK).

Use only with the stand/bracket or other mounting arrangement specified in the Product Instruction Leaflet. In case of doubt, consult with the manufacturer (Pulsar Light of Cambridge Ltd. UK).

Unplug this apparatus before lightning storms or when unused for long periods.

Refer all servicing to suitably qualified service personnel. Servicing is required when the apparatus has been damaged in any way, such as power supply cord or plug damaged, liquid has been spilled or objects have fallen into the apparatus, the apparatus has been exposed to rain or moisture, does not operate normally, or has been dropped.

DO NOT block any of the ventilation openings. Install the apparatus as specified in the Instruction Leaflet.

DO NOT defeat the safety purpose of the polarized or grounding-type plug. A polarized plug has two blades with one wider than the other. A grounding-type plug has two blades and a third grounding prong. The wide blade or the third prong is for YOUR safety. If the provided plug does not fit into your outlet, consult an electrician for replacement of the obsolete unit.

UNLESS THIS APPARATUS HAS AN IP RATING OF 65 OR GREATER

Clean only with a DRY cloth.

Protect the apparatus from dripping and splashing.

DO NOT place objects containing liquids on the apparatus.

DO NOT use this apparatus near water or in a condensing atmosphere.

Mains Supply Cable colours

Green/Yellow =  Earth / Ground

Brown = Live / Phase / Hot

Blue = Neutral / Grounded Conductor



CHROMABATTEN300

ESSENTIAL MOUNTING PRECAUTIONS

THIS WAY UP

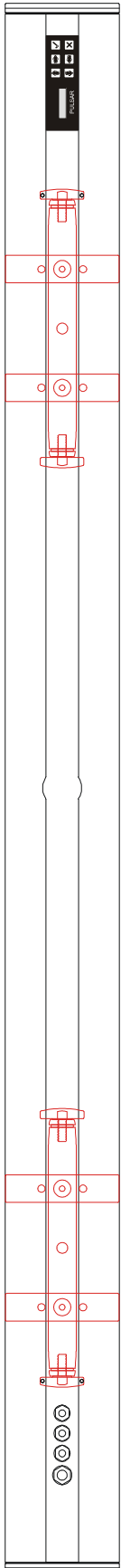

The ChromaBatten300 contains temperature sensing circuitry which scales back the current to the LEDs if the internal temperature exceeds predefined limits.

When mounting the ChromaBatten300 at an angle other than horizontal, it is essential that the cable end is at the lowest point and the display at the top (as shown in the picture to the left).

This mounting arrangement locates the internal temperature sensor at the hottest point – the top.

Failure to observe these essential mounting arrangements may result in damage to the LEDs.

Instructions

